

Name: Tyler Jones		Date: 3-7-19	Event: PNB
City: White Pine		State: TN	
Track: _____			
Track Conditions: <input checked="" type="checkbox"/> Indoor <input type="checkbox"/> Tight <input checked="" type="checkbox"/> Smooth <input checked="" type="checkbox"/> Hard Packed <input type="checkbox"/> Blue Groove <input type="checkbox"/> Wet <input type="checkbox"/> Low Bite <input type="checkbox"/> High Bite <input type="checkbox"/> Outdoor <input checked="" type="checkbox"/> Open <input type="checkbox"/> Rough <input type="checkbox"/> Loose/Loamy <input type="checkbox"/> Dry <input type="checkbox"/> Dusty <input checked="" type="checkbox"/> Med Bite <input checked="" type="checkbox"/> Other <u>Slight Moisture</u>			

Front Suspension

Toe: 2* toe out

Ride Height: 26mm

Camber: -2*

Caster Block: 17.5 20

Spindle Height: High Low

Wheel Hex: Std

Sway Bar: 2.3mm

Piston/Oil: VRP 6-hole 1.5 w/35wt

Shock Type: Bladder Emulsion Vented

Spring: EVO Blue

Pills: A0 B0

Overall Shock Length: 105mm

Drag Link/Ackerman: 1

Bump Spindle: 1mm Link: 2mm

Camber Link: 2-A

Shock Location: 2-outside

Receiver Battery Type: 2000

Weight: _____

Differentials

Front: Standard Smart

Spring Wire Dia. _____

Qty of Springs: _____

Ramp Plate: _____

Grease: _____

Diff Fluid: 7.000

Center: Standard Smart

Spring Wire Dia.: _____

Qty of Springs: _____

Ramp Plate: _____

Grease: _____

Diff Fluid: 7.000

Drive Shaft

Front: CVA UNI

Rear: CVA UNI

Arm Inserts

Front: None Plastic Carbon

Rear: None Plastic Carbon

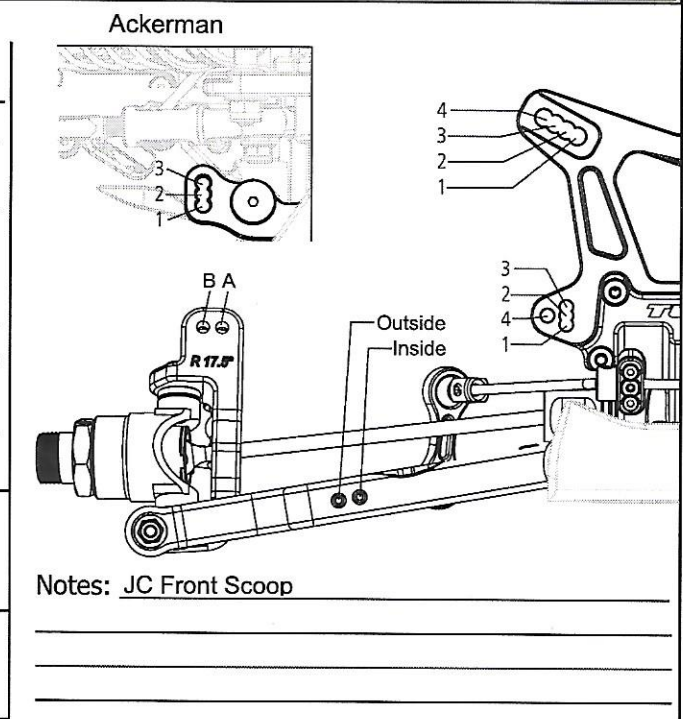

Rear Suspension

Shocks: FWD Back Shock Shaft: .35 4.0

Toe/D Pill: 0

Anti-Squat/C Pill: 0

Ride Height: 28mm

Camber: -2*

Rear Hub Spacing: All way back

Hub Height: A B Other

Wheel Hex: Std

Sway Bar: 2.5mm

Piston/Oil: VRP 6-hole 1.5 w/30wt

Shock Type: Bladder Emulsion Vented

Spring: EVO Red

Stroke: _____

Overall Shock Length: 120mm

Camber Link: 3-D

Shock Position: 3-outside

Rear Diff Fluid: 4,000

Weight: _____

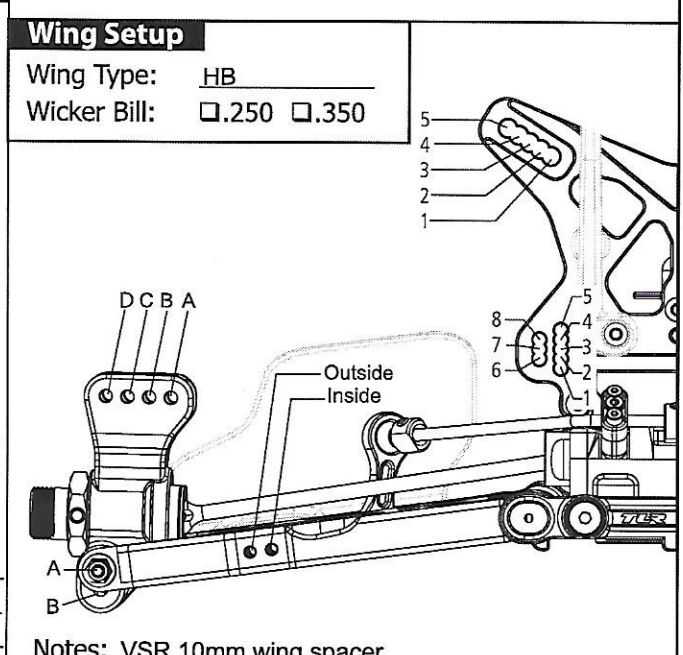

Engine

Engine: Nova Legend 4 Fuel: Bones V2 Worlds

Glow Plug: C6 Head Clearance _____

Pipe/Header: 2135 w/41001 header Gearing: Stock

Clutch

Clutch Shoes and Springs Info

2 aluminum with gold springs

2 carbon with green springs

Vented clutch bell

Tires

Type	Compound	Insert
Front: <u>JC Reflex</u>	<u>Green</u>	<u>Dirt Tech</u>
Rear: <u>JC Reflex</u>	<u>Green</u>	<u>Dirt Tech</u>

Notes: _____